

# Analogue Addressable Repeater - MFAREP Fire Detection System

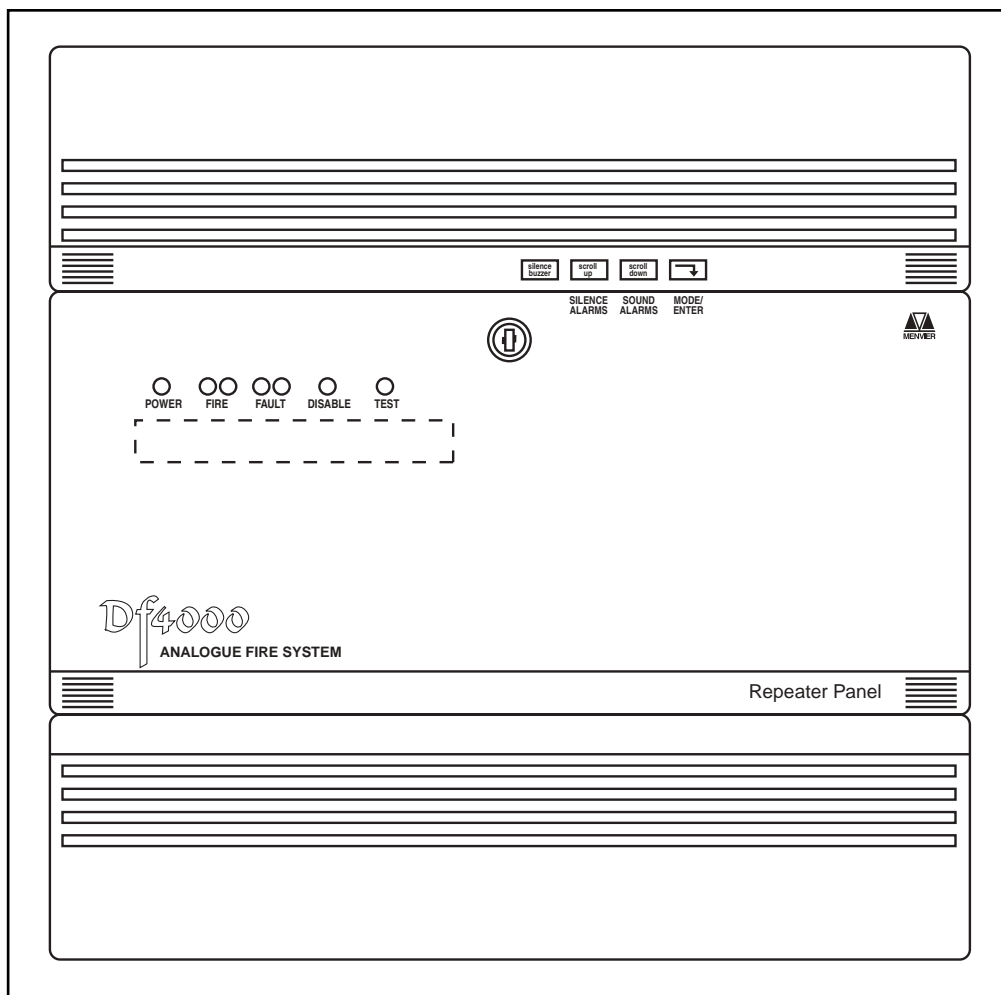

INSTALLATION INSTRUCTIONS AND OPERATING MANUAL

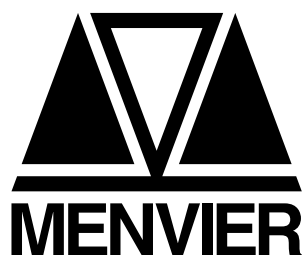

## General Description

---

The Analogue Repeater duplicates the displays and all fire fault indicators of the main AXA fire panel.

As on the main panel, if there are more than two current events, all may be viewed by using the SCROLL buttons. The main panel indicators, FIRE, FAULT, DISABLE and TEST are duplicated, however the green POWER ON indicator is not and refers to the Repeater.

The Analogue Repeater is connected to the main panel by a two wire link that may be up to 1Km long, or for the MFAREP by connection to the loop. It has an integral battery, charger and power supply and hence requires a main supply connection.

An Analogue Repeater receives data, corrects any errors it can and re-transmits the data. Analogue Repeaters may therefore be "Daisy Chained" when connect to the main panel.

## Facilities

---

### The Bleeper

The Analogue Repeaters has a bleeper that pulses sound whenever a new fault occurs, on either the main panel or the Analogue Repeater. It may be silenced with the SILENCE BLEEPER button on the Repeater.

### Analogue Repeater Fault Indicators

Repeater faults are shown on the Liquid Crystal Display (LCD). There is also a green POWER indicator showing the condition of the Repeater power supply.

### General Fault Indicator

The general fault indicator flashes when a new fault occurs, on either the main panel or the Repeater.

### Fire Indicator

The fire indicator will follow the main panel fire indicator in illumination state.

### Auxiliary Relays

There is one volt free set of relay contacts available as auxiliary relay contacts, that operate immediately a fire condition is signalled to the Repeater.

### Remote Fault Signal Relay

A set of volt free relay contacts are available and operate when a fault condition is either, signalled from the main panel or occurs on the Repeater.

## Address Repeater Controls

---

### Mode/Enter ( )

This button changes the operating mode of the Repeater.

The Repeater is normally in "ACCESS LEVEL 1" mode showing either time or first and last event but the event numbers will not be flashing. Pushing the mode button once will change to "LOG SCROLL" mode (the event numbers will flash) and pushing it again will provide "LAMP TEST".

If a fire or fault is indicated, the repeater will revert to display the first and last event otherwise it will display the time and date after lamp test mode.

### Silence/Scroll Up

In "SOUND/SILENCE" (i.e. Access Level 2) mode this button will silence alarms. In "SCROLL" mode this button will decrement through the log.

### Sound/Scroll Down

In "SOUND/SILENCE" (i.e. Access Level 2) mode this button will sound alarms. In "SCROLL" mode this button will increment through the log.

### Leaving Log Scroll Mode

Scroll mode is exited by not pressing either the Mode, Scroll Up or Down button for 10 seconds. The Repeater will then return to its normal display mode. This is only true if there are no faults or fires indicated.

### Reset

RESETTING THE ANALOGUE REPEATER SHOULD BE DONE BY RESETTING THE MAIN PANEL.

The RESET button would not normally be used. It should only be used if the Analogue Repeater hardware has locked up and resetting at the main panel does not restore normal operation. Normally, service personnel would be called if this happens, to investigate the cause. If the Analogue Repeater RESET is pressed, all circuitry is reset to a known condition and all event data is cleared from memory and the repeater "starts from scratch". This will possibly leave the Repeater and main panel with differing information on current events and hence an incorrect display on the Repeater. To warn of this condition the first log event will show "FAULT 001 REP BUTTON RESET".

## Address Repeater Fault Indication

---

### Repeater Power Indicator

The green Repeater POWER indicator shows that there is mains power applied to the Repeater when it is illuminated.

The LCD will show all other Repeater faults as text, the format for the text is as follows:

“FAULT TYPE: EVENT No: DEVICE IN FAULT: FAULT DESCRIPTION”

If the fault is with the Repeater the “DEVICE IN FAULT” section will show “REP”.

If the fault is with the main panel the “DEVICE IN FAULT” section will show “ANL”.

In the case of faults on the loop the “DEVICE IN FAULT” section will show “ZONE-NNN: LOOP-NNN: ADDR-NNN”.

## Repeater Fault Messages

---

### **Batt V Low**

This shows that the voltage across the battery is low, this may occur if the battery has been allowed to discharge for a long period.

### **Batt O/C**

This shows that the battery is not connected to the “Repeater” or that the battery fuse has failed.

### **Mains Fail**

This shows that the main electric supply to the Repeater is not connected or that a fuse has failed.

### **No Global MSG/No Address MSG**

This shows that there is no wiring to the main panel, or that the wiring is incorrect, that the main panel is not powered up.

### **System Reset**

The Repeater has been reset by the main panel.

### **Watch-Dog Rst, Power Up Rst, Button Rst**

These resets are local to the Repeater and the Repeater log will be cleared, therefore the Repeater log may not match the Main Panel Log.

### **Log Corrupted**

If this event appears in the Repeater Log any events before this point may be inaccurate.

### **Comms Parity**

This shows that the Repeater has consistently received corrupted data. If this happens, service personnel should be called to check the system.

### **Check Sum**

This shows that the Repeater’s self test system has discovered a fault and service personnel should be called.

### **Zone & Address Text**

If a zone or address has text (customer data), this will be sent to the Repeater and the display will scroll horizontally to show Address No., Loop No., Zone Text and Address Text.

Zone and Address text is only shown for the first and last event and using “LOG SCROLL” will remove the zone and address text from the display.

### **User Levels**

The MFAREP has two main user access levels 1 and 2.

Access Level 1 is available without a key and will allow the user to silence the buzzer and use the scroll mode and lamp test.

Access Level 2 will allow the user to silence or sound the alarms from the repeater, if connected to the main panel on the address loop. Access Level 2 is activated when the perspex door is opened using a key. Hence these two functions are only available to an authorised user.

## Fault Description

---

LOOP O/C	Loop Open Circuit
LOOP S/C	Loop Short Circuit
ALARM O/C	Alarm Open Circuit
ALARM S/C	Alarm Short Circuit
CHECK SUM	ROM Check Sum Error
SYSTEM COMMS	System Communications fail
WATCH-DOG	False Reset
POWER UP RESET	Power Up Reset
NO GLOBAL MSG	No Communications link
NO ADDRESS MSG	No Communications link
MAINS FAIL	Mains Fail
BATT V LOW	Battery Voltage Low
BATT O/C	Battery Open Circuit
COMMS PARITY	Error in Sent Data
PRINTER PORT	Printer Port Fault
SILENCED ALM	Alarms Silenced
RESOUND ALM	Alarms Resounded
RSI	Remote Signal Isolate Activated
SOUND ALM	Sound Alarms
CDR CHECK SUM	CDR Check Sum Error
SYSTEM RESET	System Reset
BUTTON RESET	Button Reset (at Repeater)
LOG CORRUPTED	Log Error

### Other Abbreviations

ADDR	Address
ANL	Analogue Main Panel
REP	Repeater Panel

---

## Fault Type

---

The text on the LCD has been abbreviated as follows:

FIRE	System Fire
COM FIRE	Commissioning Fire
PRE-ALARM	Pre-Alarm Condition
MISSING ADDRESS	Missing Address
L/LEVEL FLT	Low Level Fault
H/LEVEL FLT	High Level Fault
EVENT	Event
ADD ISOLATE	Address Isolate
ALM ISOLATE	Alarm Isolate
LP ISOLATE	Loop Isolate
RLY ISOLATE	Relay Isolate
CLR PRE-ALM	Cleared Pre-Alarm
CLEARED FAULT	Cleared Fault
CLR L/L FAULT	Cleared Low Level Fault
ADD ENABLE	Address Re-Enabled
LOOP ENABLE	Loop Re-Enabled
RLY ENABLE	Relay Re-Enabled
RESET	Reset
DEVICE ERR	Device Error
CLR ADD FLT	Cleared Address Fault
FAULT	Fault

## Analogue Addressable Repeater Installation Instructions

### MFAREP

The Repeater is opened by undoing the two screws located behind the perspex front door.

The front door assembly which supports the circuit board(s) can be removed by sliding to the right and lifting off the hinges. Ensure that the ribbon cable and power supply cables are removed carefully. After placing this sub-panel assembly in a safe place, remove/drill out the appropriate knock-outs at the top or the rear of the enclosure prior to fixing the panel onto the wall. Fit the batteries into the enclosure between the two brackets as illustrated in figure 1.

If the Repeater is being run from the address loop, place the correct address module in the header on the main PCB, then replace the sub-panel in the main box. Do NOT connect the Earth link to the PCB as this will cause the panel to show "LOOP S/C".

If the Repeater is being run from the serial communication port, of the main panel the Earth link should be connected from the screw that holds the sub-panel to the back box, to the terminal block on the PCB marked "GND".

When all external circuit wiring has been completed, connect the leads to the battery terminals ensuring correct polarity (red lead: positive) and check that the low voltage AC supply from the transformer is connected to the circuit board. Now, connect the battery connectors to the circuit board (the charging current of the circuit board capacitors may cause a small spark to be seen in the connector which is quite normal). The fault lamp will now flash and the internal bleeper will sound. Refit the front door assembly and switch on the mains and if all is well the only lamp to be illuminated will be the "POWER ON" lamp and the LCD will show:

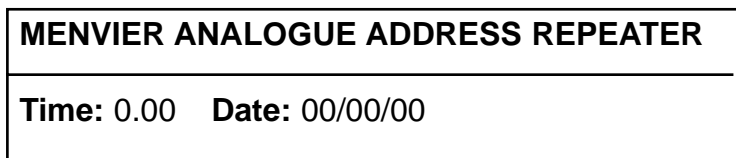

### MFAREP

If both the Repeater and the main panel are powered up the Time and Date on the Repeater should be updated to show the correct time.

<b>WARNING:</b> Opening up of any of the panels after installation should only be carried out by a suitably qualified/trained person. Live parts are exposed by this operation so therefore, ensure that the mains supply is switched off before attempting to service any of the parts inside the panel.
---

---

## Repeater Debug Mode

---

Debug mode allows an analogue repeater running software AR2V1R6 or higher to “look” at the pulses transmitted by the loop controller. Time details about the pulses including corrupted pulses and pulses with invalid lengths are displayed on the LCD, or with the addition of a printer, debug mode can log these details and the time that they occurred.

Debug mode can be set up to look at a specified address and log all faults at that address (a scope can be triggered at that address - connect scope to R62) or it can be set to look at all addresses on the loop, or +ve end of test LED resistor on small repeaters.

To enter debug mode:

Press “mode” until lamp test  
Press “next” at the same time

Debug mode can only be entered if there are no faults on the repeater.

The following abbreviations are used on the printer and LCD:

O	If this is flashing the loop controller is sending pulses.
G	Global repeater message being sent.
SA	Selected address (o=any) use “NEXT” and “LAST”.
PT	Address pulse length (*9.6uS) of selected address.
PG	Address pulse to address pulse length (*0.001mS) of selected address.
CC	Total address count for loop.
AC	Address of analogue communication.
LI	Number of length invalids since entering debug mode.
LC	Number of length corrupted since entering debug mode.
CA	Last corrupted/invalid address.
PL	Length of last corrupted/invalid pulse (*9.6uS)

## Repeater Debug Mode (continued)

---

The repeater is best placed at the end of the loop

An average "PT" is:

26-27 for a "Normal" address increment

An average "PG" is:

05-06 for a non analogue device (normal reply)

07-08 for an analogue device (normal reply)

07-08 for a toggled MIO

07-08 for a non analogue device in fire

08-09 for an analogue device in fire

15-16 for an MPU receiving a sound/silence command

40-42 for an analogue device "talking" to the L.C.

To exit debug mode press "Mode"



# DF4000 Repeater Panel Front View

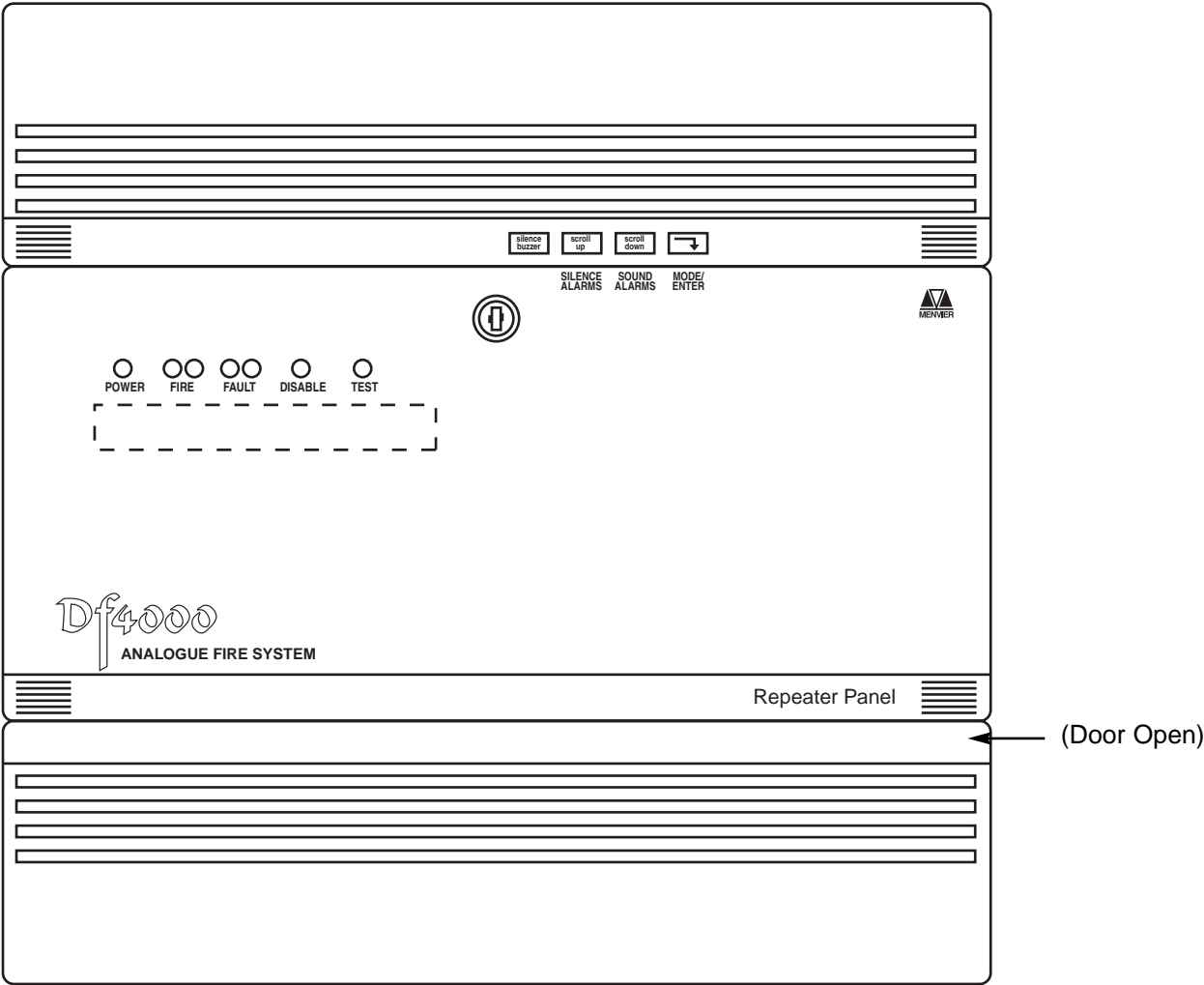

## Diagram Showing Component Layout of Repeater Panel

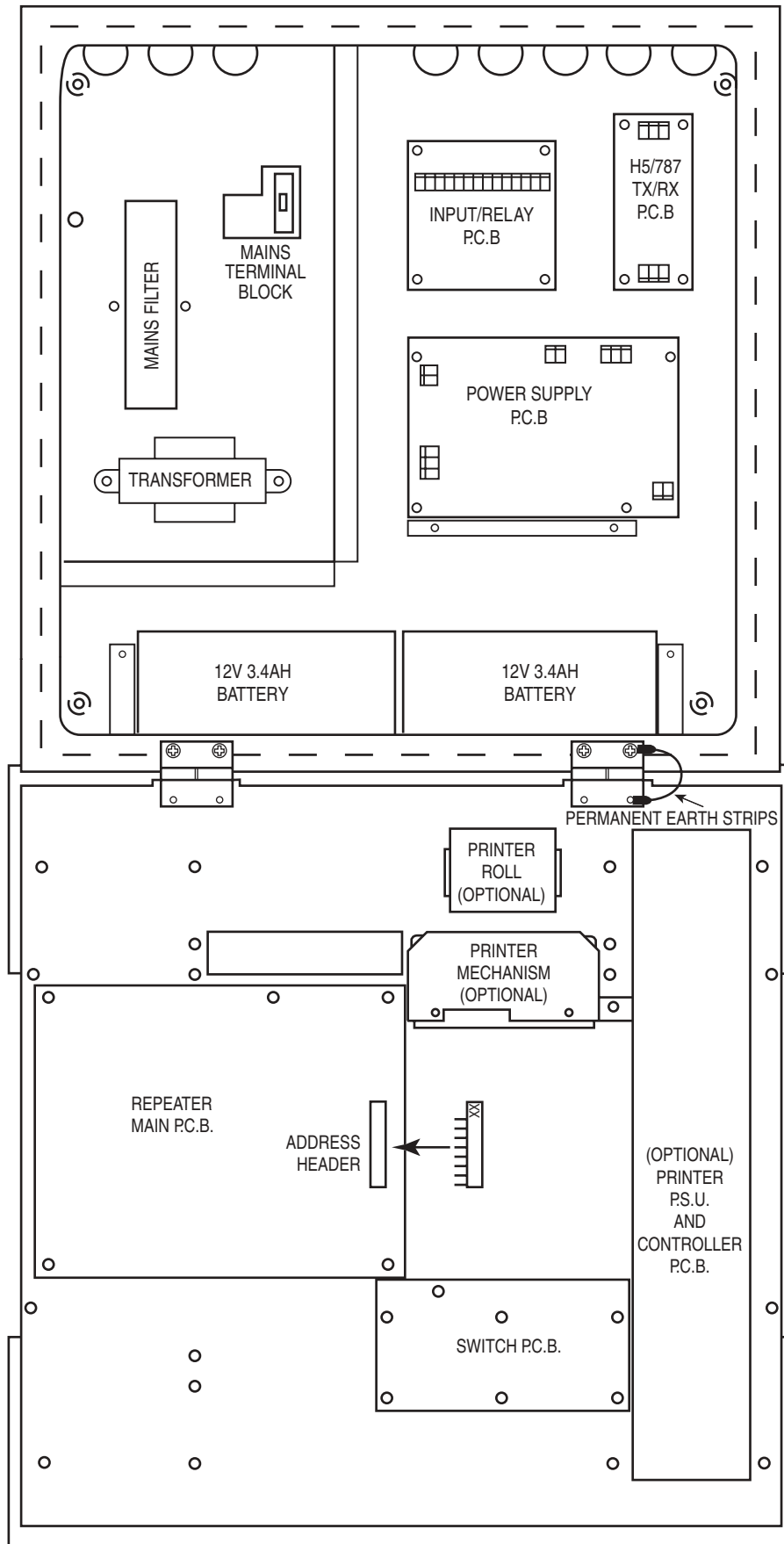

# Main Enclosure Dimensions for DF4000 Repeater Panel

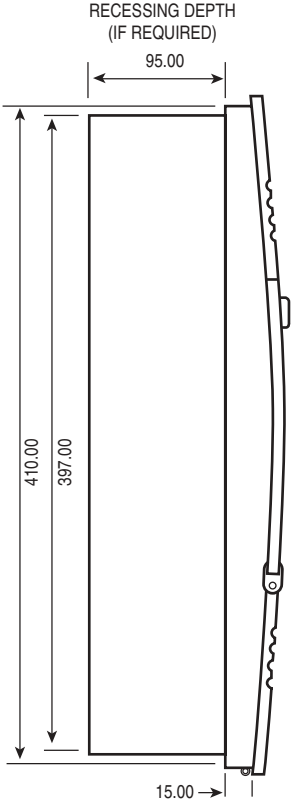
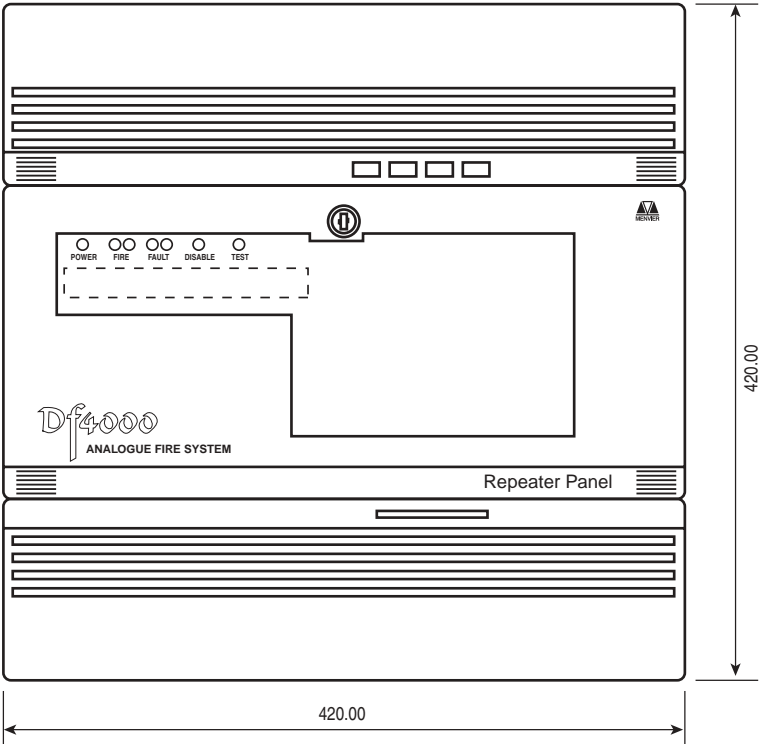
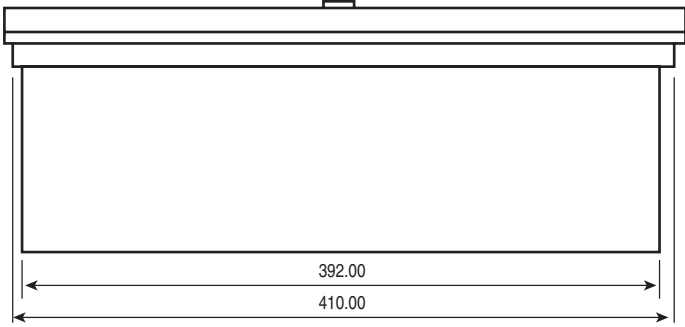

## Connection of MFAREP to Serial Comms

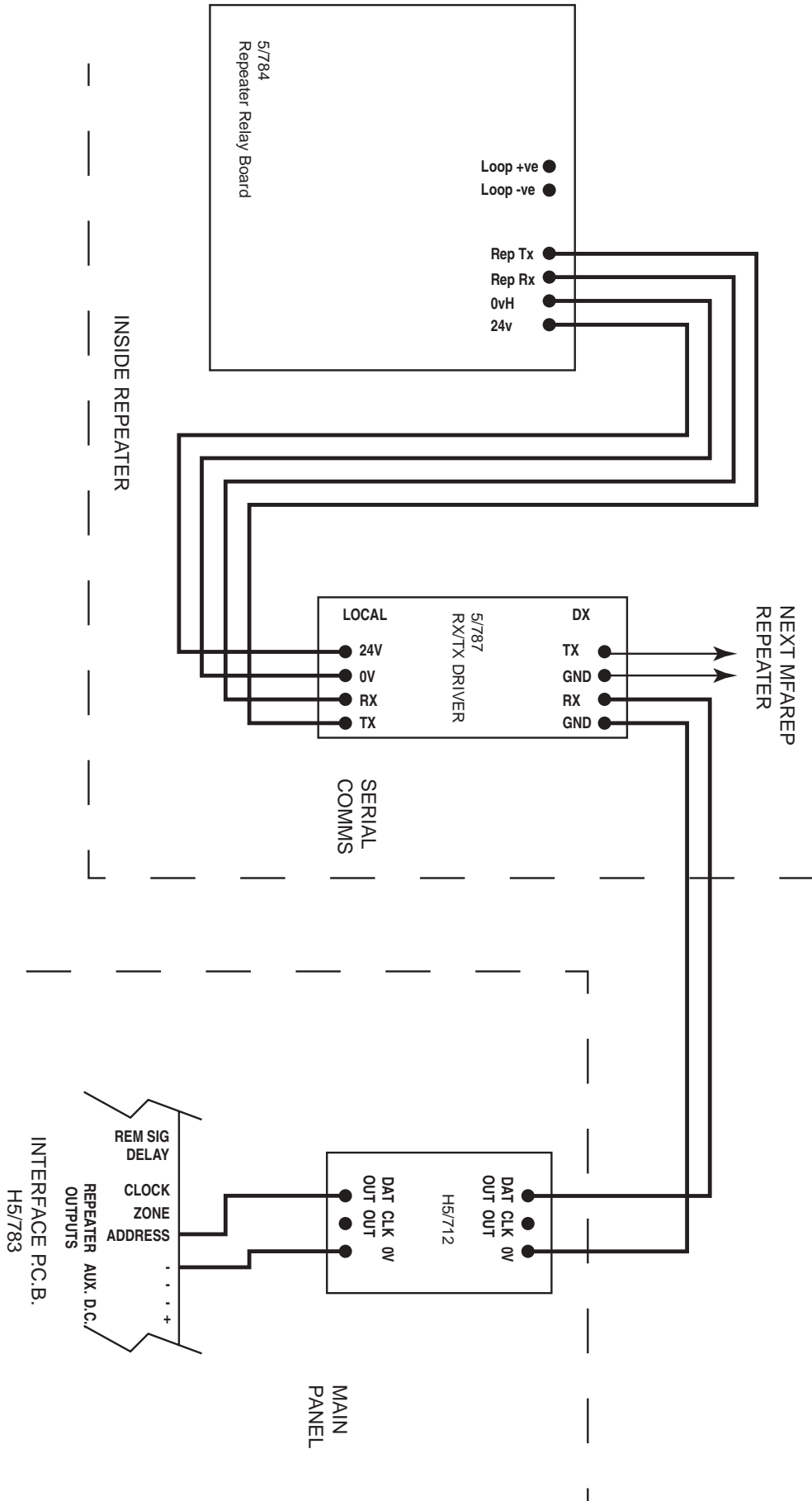

## Connection of 5/712 board in main MFAXA Panel

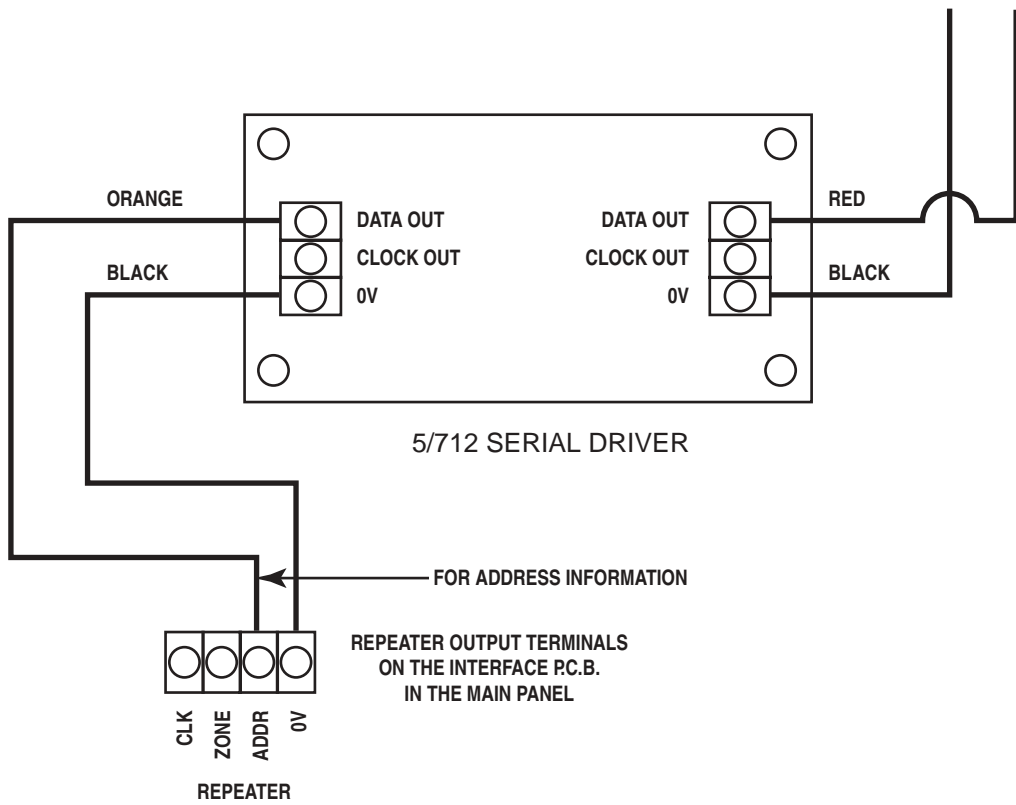

## Connection of a MFA Repeater to Loop

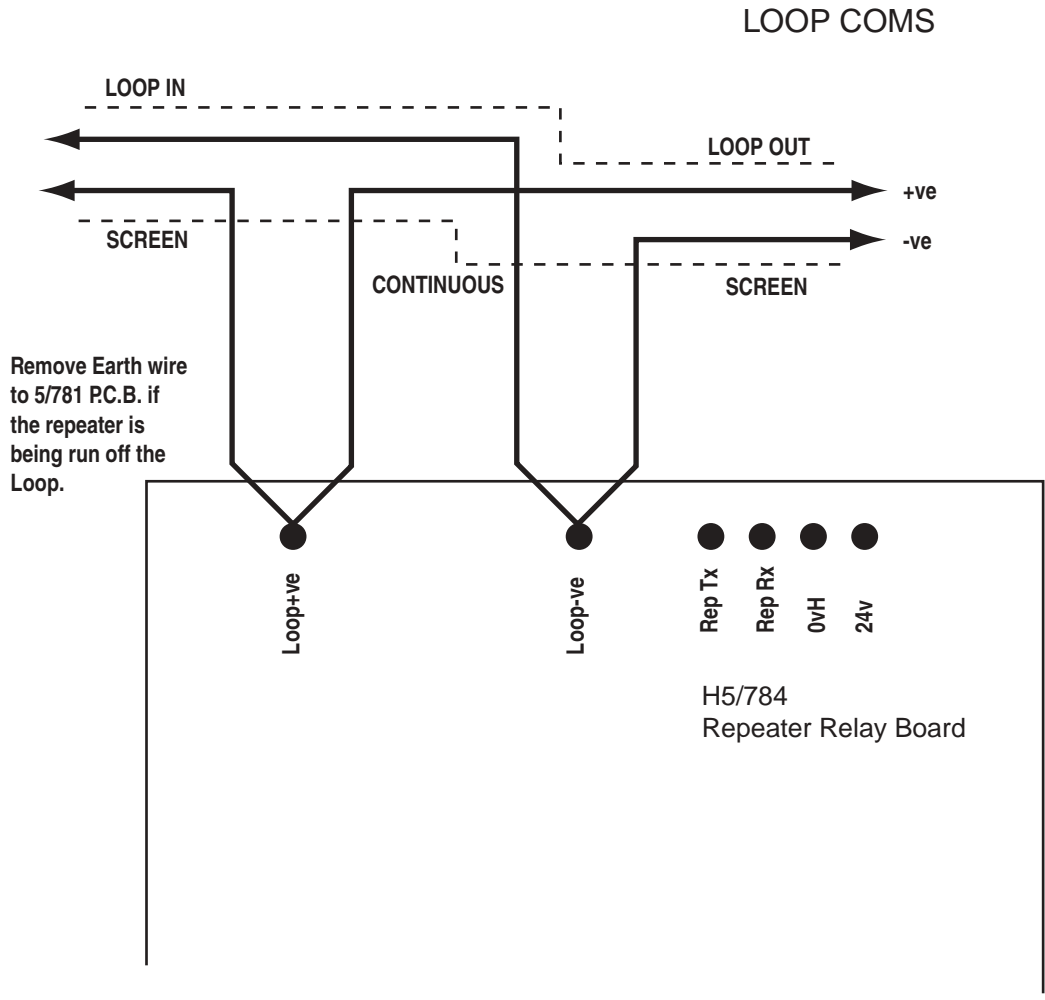

# MFAREP Menu

## MFAREP

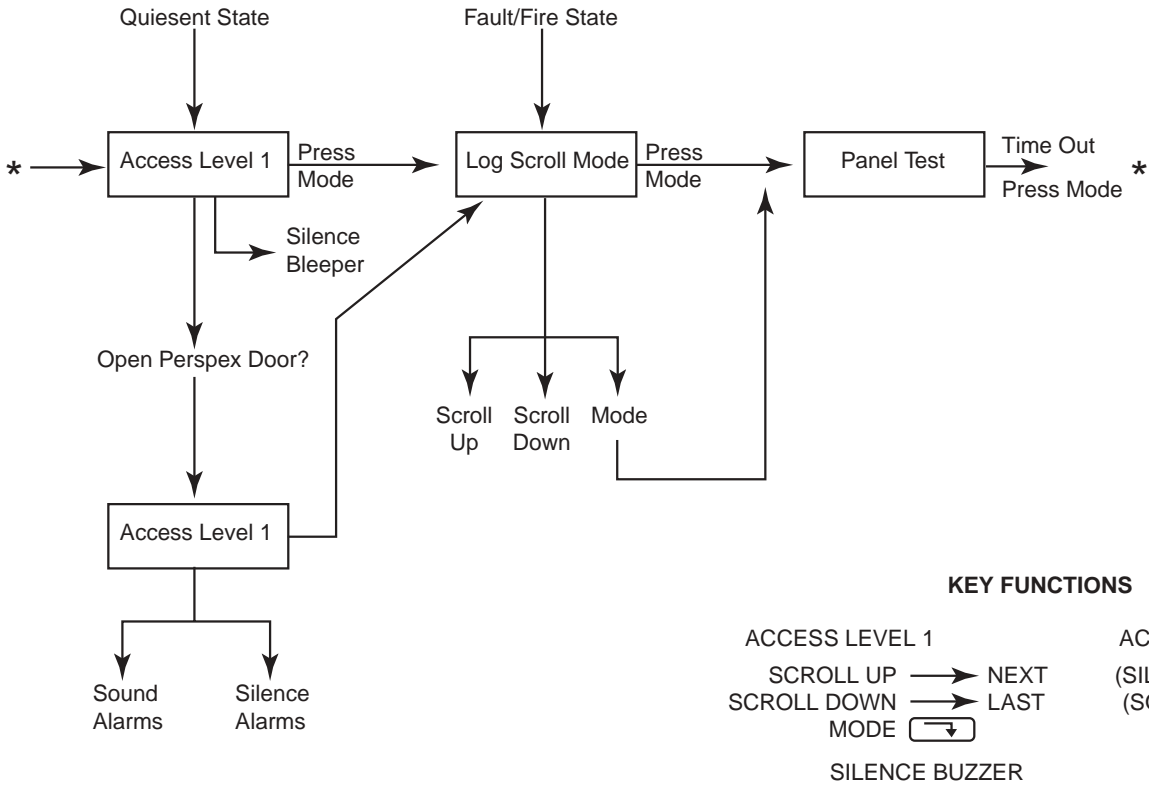

---

# **COOPER** Lighting and Security

## **Cooper Lighting and Security Ltd.**

Wheatley Hall Road, Doncaster, South Yorkshire, DN2 4NB, United Kingdom

### **Sales**

Tel: +44 (0)1302 - 303222  
Fax: +44 (0)1302 - 367155  
Email: [sales@cooper-ls.com](mailto:sales@cooper-ls.com)

### **General**

+44 (0)1302 - 321541  
+44 (0)1302 - 303220  
[technical@cooper-ls.com](mailto:technical@cooper-ls.com)

### **Export**

+44 (0)1302 - 303250  
+44 (0)1302 - 303251  
[export@cooper-ls.com](mailto:export@cooper-ls.com)



PINST MFAREP 2/V1

[www.cooper-ls.com](http://www.cooper-ls.com)